







DSX-1048PKG

Intelligent Controllers

- Scalable Architecture from 2 - 8 doors
- TCP/IP Communications
- Individual Intelligence
- 512K RAM / 512K Flash ROM
- UL 294     
- 185+ Card and Keypad Formats
- Real Time Processing and Communications
- Integrated Power Supply and Distribution
- Compatible with all existing DSX Controllers



General Information

The DSX-1048PKG Intelligent Controller is an independent processing 8 door package designed to be a cost effective building block platform that allows expansion in a scalable manner. Up to 8 doors can be controlled from 1 enclosure for an efficient space saving package. The controllers are strategically placed throughout the customer location connected together with a two twisted pair cable. Each DSX-1048 operates as a fully intelligent and independent controller that retains all data necessary for system operation in its own RAM. With its integral real-time Clock and Calendar it performs Time Zone control with Holiday overrides for inputs, outputs, and cards even when communication to the PC or other controllers is not available. The DSX-1048 carries a Limited 2 Year Warranty.

Controller Architecture

The DSX-1048 Intelligent Controller may be used in conjunction with all other DSX Controllers as a Master or Slave in the controller network. Any controller may be designated as a Master or Slave controller. The Master or Slave mode of operation is determined by the panels dip switch settings. The first panel of each location is designated as the Master while all others would be considered Slaves. The Master is responsible for communications to the PC and to the Slave panels. Up to 16 - DSX-1048PKG Intelligent Controllers can be used in a single Location providing for 128 readers. Multiple Locations can be grouped for systems that require more than 128 readers/keypads.

Each DSX-1048PKG includes a DSX-1040E Enclosure, a DSX-1040CDM Communication Distribution Module and 4 DSX-1042 Intelligent Controllers. Each DSX-1048 provides 8 Reader Ports, 32

Inputs, and 16 Outputs. Each DSX-1042 has a 12 volt fused power output for its Card Readers and Keypads. The DSX-1042 contains an AM186 processor, 512K of RAM, 512K of Flash ROM, and a Real Time Clock. The DSX-1048 allows all door and field wiring connections to be made via removable terminal blocks. The DSX-1040CDM receives RS-485 communications from a possible previous panel and regenerates the 4 wire-RS485 to the next DSX-1048PKG. The DSX-1040CDM also distributes Slave Controller communication to those Slave panels located within the same enclosure.

Used in conjunction with the DSX-1048PKG Intelligent Controller is a DSX-1040PDP or Power Distribution Panel. The DSX-1040PDP houses the controller and lock power supplies, backup batteries, and fused power distribution module. The DSX-1040PDP is comprised of a DSX-1040PE enclosure, an AS-150 15V power supply for the controllers, an AS-150[15] or [27] for either 12V or 24V locks, and a DSX-1040PDM or Power Distribution Module.

System Power

Each Controller in the DSX-1048PKG is powered from an individually fused 12 volt output from the DSX-1040CDM distribution module located in the same enclosure. The module also provides 5 volt power for those Readers and or Keypads that require it. The DSX-1040CDM receives power from the DSX-1040PDP Power Distribution Panel. The DSX-1040PDP houses the controller and lock power supplies, backup batteries, and fused power distribution module. The DSX-1040PDP is comprised of a DSX-1040PE Enclosure, an AS-150 15V power supply for the controllers, an AS-150-[15] or [27] for either 12V or 24V locks, and a DSX-1040PDM Power Distribution Module. The DSX-1040PDM

performs several critical functions. First, it takes the 15V power from the AS-150 and provides two 4A Class II, Power Limited, fused outputs to power the DSX-1040CDM which distributes the power to the DSX-1042 Controllers in the DSX-1048PKG. It provides a 12V Battery Charging Circuit to charge backup batteries for the controllers. It also provides a charging circuit for the optional batteries used to backup the 12 or 24 volt lock power from the AS-150 power supply. The Power Distribution Module has 3 N.C. Relay Outputs, two to signal Loss of AC (one for lock power and one for controller power) and one to signal Low Battery. These Outputs can be connected to spare Inputs in the DSX-1048PKG. The module also has a Battery Test Input. This Input when activated shuts off the charging circuit and load tests the battery for 1 minute. This Input can be connected to a spare Output in the DSX-1048PKG and programmed by time zone to occur when desired. The DSX-1040PDM routes Lock Power through individual fuses for each of the 8 Class II, Power Limited, outputs. The module also has an input for a Fire Override relay contact to break Lock Power and has a Fire Override Output to connect to the next 1040PDM. All Outputs are Class II, Power Limited.

Reader Technologies

The DSX-1048 is compatible with Wiegand, Barium Ferrite, Proximity, Bar Code, Magnetic Stripe, Biometric, and Smart Card readers. Any combination of reader technologies may be used in the same system. A keypad may be added to most readers to create a card and/or PIN controlled entry point. The DSX-1048 is compatible with over 185 different card readers / keypads and card formats which makes it the perfect panel for retrofits. Conversion modules exist for some types of other manufacturers proprietary card readers. The panel is compatible with two wire wiegand and clock and data outputs without the use of any modules. Each reader port has 3 LED open collector outputs for Door Secure, Door Open, and Access Denied/Keypad PIN Entry. This will accommodate almost any reader and LED configuration. It is possible to connect the sounder control line of most card readers directly to the Pre-Warn output for door held open annunciation.

Memory

Each Controller has a standard configuration of 512K of Flash ROM and 512K of RAM. The RAM memory allocation is dynamic between database and event storage and set for optimum use by the Host PC according to data entered for that location. Flash ROM allows for the Controllers' operating system to be upgraded without the changing of chips (EPROMS). Having 512K of RAM eliminates the necessity of increasing the memory in controllers as the system grows. When the Controller is in service the amount of RAM and the version of ROM can be viewed from the DSX communications software.

Inputs

The DSX-1048PKG has 32 EOL supervised Inputs capable of two, three, and four state point monitoring with trouble reports. The armed status of each Input can be controlled by up to 4 Time Zones, I/O & Card Linking, and Manually from the PC. Eight Inputs are designated as Door Position and eight Inputs are designated as Exit Request Inputs for the reader controlled doors. The remaining sixteen Inputs are then left for additional monitoring points.

Outputs

The DSX-1048PKG has 16 Programmable Outputs. Eight Outputs are

Form-C, 5 Amp rated relays used to control the locks for the reader controlled doors. Eight Outputs are the open collector type, both have an LED for status and are fully programmable. In addition to the 16 programmable Outputs there are 8 Pre-Warn Outputs, (1 for each door) and are used to indicate the reader controlled doors are being held open and are about to go into alarm. Once the door is opened the Output begins pulsing low starting at 1/3 of the door open too long time and changes to a steady low anytime the door is in alarm. These open collector (switched negative) Outputs reset automatically when the door is closed.

Communications

The DSX-1048PKG Intelligent Controller can communicate with the WinDSX Communications Server via TCP/IP LAN communications, Direct Serial Port connection, and Dial-Up Phone Modem.

TCP/IP LAN Communications can be performed from the WinDSX Comm Server PC to a Master Controller. The WinDSX Software without the use of any additional Hardware or Software will redirect what would typically be serial port communications to a TCP/IP address. A DSX-LAN(M) serial device at the Master Controller receives the communications over the LAN from the WinDSX PC and converts it to RS-232/RS-485 for the Master Controller. The end result is real time communications similar to that of a direct serial port connection.

Direct Connect Communications from the PC to the Master Controller is performed with a connection from the Host Port of the Master to a serial port of the PC. RS-232 is used for short distance connections. RS-485 communications is used when the direct serial port connection is from 50 to 4000 feet from Controller to PC. In order to communicate with the Master Controller with RS-485 communications requires two MCI modules. One DSX MCI module is placed at the PC to convert the RS-232 signal to RS-485 and a second module is placed at the Master Controller to convert the RS-485 back to RS-232. The Controller communicates with the PC at a default baud rate of 9600.

Dial-Up Modem Communications from the DSX-1042 Master Controller to the PC utilizes a DSX modem at the Controller and one at the PC. At the DSX-1042 Master, the RS-232 Host Communications Port connects to the Modem. The Modem derives its power from the DSX-1042 panel. The Controller will auto-dial to the PC all Alarm and Supervisory conditions. The Controller can also be programmed to dial the PC when its event storage buffer is 80% full.

Controller Communications is handled at each DSX-1048 by a DSX-1040CDM (communications distribution module) using true point to point, regenerative, RS-485, 4-wire communications. This module has 2 RS-485 ports for in and out 4 wire communications to other Controllers. The Controller network communications is regenerated at each DSX-1040CDM allowing up to 4000 feet of distance between Controllers over two twisted pair cable. The DSX-1040CDM has 2 RS-232 Communication Ports. One is used to connect to the Master Controller and is only used in the DSX-1048PKG Enclosure where the Master Controller resides. The other RS-232 port connects to the RS-232 port of each Slave Controller in that same enclosure. DSX-1048PKG Controllers are connected in a series loop configuration unless a DSX-1035 Quadraplexor is used for Star wiring.

DataBase Downloads

The Controllers utilize a synchronized database that is maintained with the incremental and automatic or scheduled downloading of changes only. This intelligent, independent processing increases the speed of the panels actions and reactions, providing more stability and security to the overall system. The Controllers are downloaded with all parameters the first time they are brought on-line. Once the initial full download occurs all database changes such as the adding and deleting of card holders are sent to the Controllers by way of incremental downloads. The Controllers' transaction buffer automatically adjusts its size to utilize any RAM not allocated for data.

Diagnostic, Supervisory and Status LEDs

The DSX-1048 has 88 diagnostic LEDs to indicate panel status. Thirty two are for Input Status, sixteen are for Output Status, the rest are for Communications, Fuse Status, and Processor Status.

Input / Output / Code Linking

The DSX-1048PKG has powerful Linking capabilities that provide flexible input and output control. Codes, Inputs, and Outputs can Link to other Inputs and Outputs, on the same or different controller, in order to control their armed or on and off state. Linking to Inputs allows for control of their armed state. Linking to Outputs allows for control of their on/off state. Linking responses include: Pulse, Latch, Follow, Toggle, and Time Zone. Inputs can Link to Inputs and Outputs. Outputs can Link to Outputs and Inputs. Codes can Link to both Inputs and Outputs. All I/O Linking is performed at a local (panel) as well as a global (location) level.

DSX-1048 Specifications

Size

DSX-1040E Cabinet	15.5" W x 22.5" H x 6" D
DSX-1040CDM	11" W x 4.5" H x 1.5" D
DSX-1042	11" W x 4.5" H x 1.5" D

Weight

DSX-1040E Cabinet	19.2 lb.
DSX-1040CDM	1.0 lb.
DSX- 1042	1.2 lb.
DSX-1048 - Total	25.0 lb.

Finish

Black Powder Coat with White Silkscreen on Enclosure and Black Enamel on DSX-1042.

Conduit Knockouts

Concentric knockouts in Top, Bottom, and Sides.
Knockouts accommodate 1/2, 3/4, 1, 1 3/4 inch conduit.

Temperature

Operating	32 to 131 F
Storage	-35 to 150 F

Humidity

Operating 0 to 95%, relative

Power Requirements

DSX-1042	13.5 VDC @ 300ma from 1040CDM
DSX-1040CDM	13.5 VDC @ 150ma from 1040PDP
Total Maximum Current	13.5 VDC @ 8.0A

Output Voltage

Panel outputs provide a regulated, fused, DC voltage.

DSX-1042	9-13.5VDC - 12VDC nominal - 1A Fused
DSX-1040CDM	9-13.5VDC - 12VDC nominal - 1.5A Fused
DSX-1040CDM	5VDC - .5A Fused

All Outputs are Class II, Power Limited

Inputs

EOL Supervised 32

16 Inputs are used for standard point monitoring.

16 Inputs are used for door position and exit request monitoring.

All Inputs support two, three, and four state monitoring with five programmable circuit types.

UL Installations require a Tamper Switch to be connected to an Input programmed with a 24hr Time Zone.

Outputs

Form C Relays	8
Relay Output Ratings	5 AMP - 30VDC
Open Collector Outputs	8 - negative 100ma
LED Outputs	24 - 3 per reader port - negative 100ma
Pre-Alarm Outputs	8 - 1 per door - negative 100ma

Access Controlled Entry Points

Card Reader or Keypad 8
Card and Reader Formats 185+
Any combination of card readers, keypads, or card and keypad controlled entry points may be used.

Communication Ports

DSX-1042		
RS-232 In	1	Master to PC
RS-232 Out	1	Panel to DSX-1040CDM
1040CDM		
RS-232 In	1	Master to DSX-1040CDM
RS-232 Out	1	Slave Communications
RS-485 In	1	From previous DSX-1048 Package
RS-485 Out	1	To subsequent DSX-1048 Packages

Processor

AM186 20Mhz

RAM/ROM Memory

Flash ROM	512K
Standard RAM	512K

Warranty

Limited 2 Years

1048PKG Intelligent Controller Package

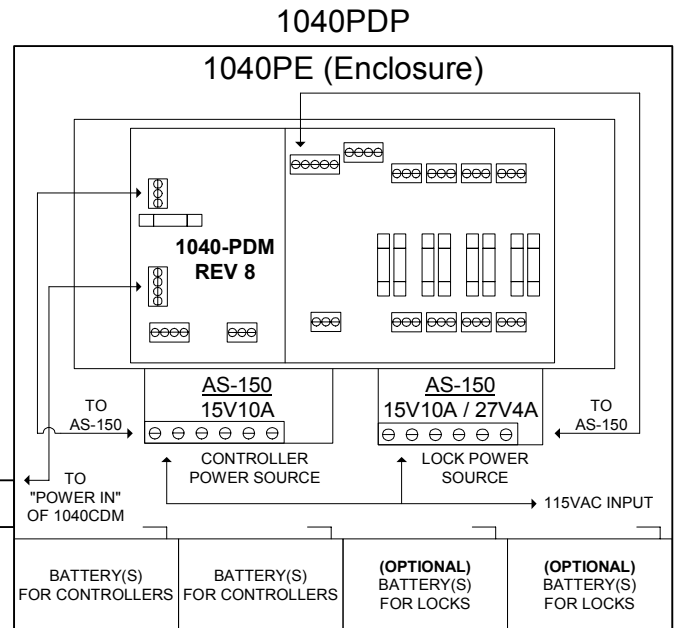
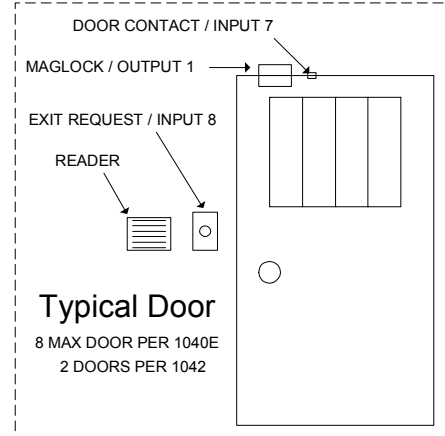
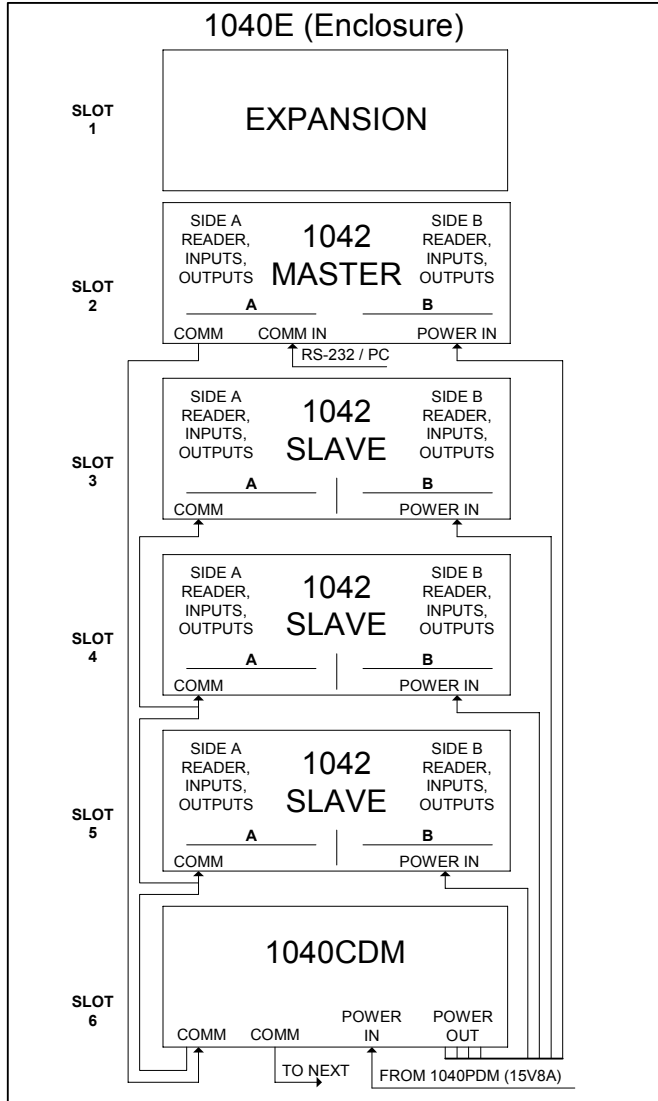

The DSX-1048PKG includes a DSX-1040E Enclosure, a DSX-1040CDM Communication Distribution Module and 4 - 1042 Intelligent Controllers. This provides 8 Reader Ports, 32 Inputs, and 16 Outputs. The DSX-1048 Package comes complete with 32-1K ohm EOL Resistors, Lock & Key, Wire Ties, Tamper Switch, an External Power Indicator and a DSX-1040PDP Power Distribution Panel.

The DSX-1040CDM receives RS-485 communications from a possible previous panel and regenerates the 4 wire-RS485 to the next DSX-1048PKG. The DSX-1040CDM module also distributes Slave Controller communication to the Slave panels within the same enclosure. Each DSX-1042 is powered from an individually

fused 12 volt output from the DSX-1040CDM Communications Distribution Module. The DSX-1040CDM receives power from the DSX-1040PDP Power Distribution Panel.

Used in conjunction with the DSX-1048PKG is a DSX-1040PDP or Power Distribution Panel. The DSX-1040PDP houses the panel and lock power supplies, backup batteries, and fused power distribution module. The DSX-1040PDP is comprised of a DSX-1040PE Enclosure, an AS-150 15V power supply for the Controllers, an AS-150-[15] or [27] for either 12V or 24V locks, and a DSX-1040PDM. The DSX-1040PDM performs several critical functions such as supervising Power Supplies and Batteries, distributing power through fused outputs, and providing battery charging circuits. All Outputs are Class II, Power Limited.